

# Oscillators

## 3.0 AF Sine Wave Oscillators

### Introduction

What you'll learn in Module 3

[Section 1.0 Oscillator Basics.](#)

[Section 3.0 Introduction.](#)

- Fixed Frequency RC Oscillators.
- Variable Frequency RC Oscillators.

[Section 3.1 The RC Phase Shift Oscillator.](#)

- Phase Shift Networks.
  - Cascaded High Pass Filters.
  - Cascaded Low Pass Filters.
- Frequency of Oscillation.
- RC Phase Shift Oscillator Using a Bipolar Transistor.
- Buffered Phase Shift Oscillator.

[Section 3.2 Phase Shift Oscillator Practical Project](#)

- Building a Phase Shift Oscillator.
- Phase Shift Oscillator Tests & Measurements.

[Section 3.3 The Wien Bridge](#)

- Operation of the Wien Bridge Circuit.
- The Variable Frequency Wien Bridge.
- Development of the Wien Bridge Oscillator.

[Section 3.4 Wien Bridge Oscillators](#)

- Lamp Stabilised Wien Bridge Oscillator.
- Diode Stabilised Wien Bridge Oscillator.
- Wien Bridge Oscillator With AGC.

### Fixed Frequency RC Oscillators

Single Frequency Oscillators that produce a sine wave output at audio within the frequency audio band have many uses. Audio oscillators are also used



to produce sounds such as the simple warning beeps in anything from automobiles to airliners. Oscillators may produce a single sine wave with a carefully controlled frequency, or may output a range of frequencies by having multiple frequency controlling elements, such as RC filters, selected by a series of switches or keys, and have their wave shape manipulated by extra circuitry for use in such systems as electronic keyboards..

### Variable Frequency RC Oscillators

Audio oscillators produce waves having frequencies from about 20Hz to 20kHz (the audio spectrum) and up to about 100kHz for



ultrasonic purposes. Variable frequency oscillators

are used in audio signal generators that are essential for testing amplifiers and fault tracing in many electronics systems. The RC oscillators used for these applications can be capable of producing signals up to around 1MHz or more.

### Typical RC Oscillator Frequencies

Although there is some crossover of the frequencies that can be produced by high frequency RC and low frequency LC oscillators, at frequencies below about 100kHz it becomes less practical to use LC tuned circuits, because the physical size of inductors and capacitors required for resonance at these frequencies becomes too large. Lower (audio) frequency oscillators therefore use various designs of RC filter circuits to produce the necessary phase shifts in the feedback path from the output to input of the amplifier section of these oscillators.

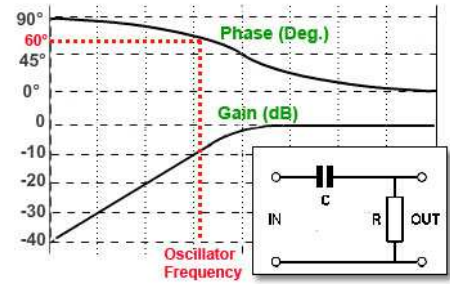

## Oscillators – Module 3

### 3.1 The Phase Shift Oscillator

#### What you'll learn in Module 3.1

After studying this section, you should be able to:

- Understand the operation of a Phase Shift Oscillator.
- Describe the effects of using multiple filters on the frequency of oscillation.
- Know relevant formulae for the frequency of oscillation.
- Describe the advantages of buffered phase shift oscillators.

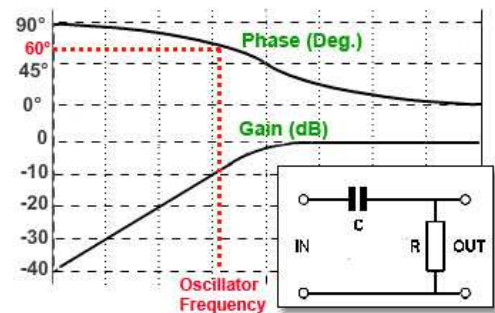

Fig. 3.1.1 High Pass

#### The Phase Shift Network

This circuit uses the property of RC filters to cause a phase shift, and by using multiple filters, a feedback circuit with exactly 180° phase shift can be produced. When used with a common emitter amplifier, which also has a phase shift of 180° between base and collector, the filters produce positive feedback to cause oscillation to take place. The RC network commonly used is that of a high pass filter, (Fig. 3.1.1) which produces a phase shift of between 0° and 90° depending on the frequency of the signal used, although low pass filters can also be used.

If a number of identical filters are used in cascade, with the output of one filter feeding the input of the next, as shown in Fig. 3.1.2 a total phase shift of exactly 180° will be produced at one particular frequency. Usually three filters are used with each filter producing a phase shift of 60° at the required frequency.

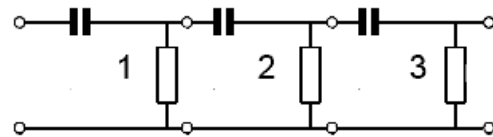

Fig. 3.1.2 Three Cascaded High Pass Filters

As any single high pass filter can produce a phase change of up to 90°, it would seem that, in theory, only two such networks, would be needed. However, using two filters with each producing a 90° phase shift would mean that, as the phase graph in Fig. 3.1.1 shows, the phase response curve is quite flat at and above 90°, so any drift in frequency would have little effect on the 180° phase shift produced. This would mean that if the frequency of the oscillator changes, due to a change in temperature for example, there would be hardly any change in the amount of phase shift, so frequency stability would be poor. It can be seen from Fig. 3.1.1 that at 60° or 45° the phase response curve is much steeper, and so with three filters producing 60° each, or four filters providing 45° each, to make up the required 180°, frequency stability will be much better.

Using multiple filters in this way does create other problems however. The frequency of oscillation can be worked out by a fairly simple formula,

$$f_o = \frac{1}{2\pi(\sqrt{6})CR}$$

But because this formula is based on calculations for individual filters, it does not fully take into account the effect of connecting the filters in cascade, which causes one filter to be 'loaded' by the input impedance of the next, as shown in Fig.3.1.3, where the input impedance of filter 2, made up of the reactance ( $X_C$ ) of C2 and the resistance of R2 effectively changes the value of the output resistor of filter 1 (R1) as they are effectively connected in parallel with it. Changing the output impedance of the filters in this way causes the frequency at which the filter produces the required phase shift to change, so altering the oscillator frequency. The more filters that are cascaded the worse the effect becomes, also making it more complex to accurately calculate the frequency of the phase shift oscillator.

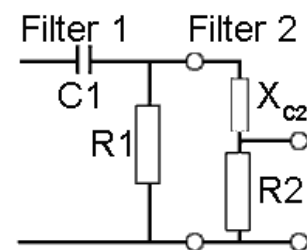

Fig. 3.1.3 Loading Effect

In addition to the loading effect caused by the cascaded filters, the input impedance of the amplifier also contributes to the overall loading on the phase shift network. This loading caused by the amplifier can be minimised however, by ensuring that the amplifier has as high an input impedance as possible, for example using an op-amp instead of a BJT amplifier.

Due to the loading effect caused by the use of multiple filters and the added complexity of an additional filter, the four-filter 45° phase shift model is seldom used, even though using four filters does give slightly better frequency stability. Also the poor frequency stability of the two-filter model makes the three-filter oscillator the most usual choice.

### RC Phase Shift Oscillator Using a Bipolar Transistor

The circuit shown in Fig. 3.1.4 uses three high pass filters (C3/R4, C2/R3 and C1/R2) to produce 180° phase shift. A sine wave of approximately 3Vpp with minimum distortion is produced across the load resistor R5. The frequency of oscillation is given by:

$$f_o = \frac{1}{2\pi(\sqrt{6})CR}$$

In several tested practical examples of this circuit, the actual frequency produced was within 7% of the calculated value.

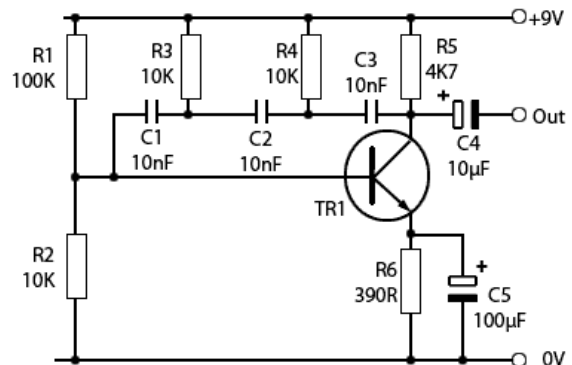

Fig. 3.1.4 BJT Phase Shift Oscillator

The basic BJT phase shift oscillator is a useful as a source of low frequency sine waves but does have a number of drawbacks:

- There can be quite a wide difference between the calculated frequency value and the actual frequency produced.
- The waveform amplitude is generally not well stabilised so a good wave shape is not guaranteed without additional circuitry.
- They are difficult to design in variable frequency form as this would involve [ganging](#) together either 3 variable capacitors or 3 large variable resistors, and such components are not readily available.

### Buffered Phase Shift Oscillator

An improvement on the standard BJT version of the phase shift oscillator is obtained by using op amp buffers to reduce the loading on the phase shift filter circuits.

The circuit shown in Fig. 3.1.5, based on a design in the excellent “[Op Amps for Everyone](#)” Design Reference from [Texas Instruments](#), uses one section (IC1a) of a quad Op Amp package for an amplifier with a gain of just over 8 (R2 ÷ R1) to replace the 1/8 losses in the three filters.

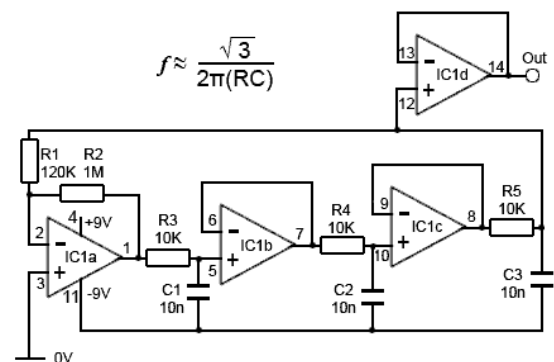

Fig. 3.1.5 Op Amp Buffered Phase Shift Oscillator

IC1 b and c provide non-inverting buffers (each with a gain of 1) so that the filters R3/C1 and R4/C2 are loaded only by the extremely high impedance of the op amp input. While the output of the circuit could be taken from the junction of R5/C3, this point has a high impedance and is therefore not able to drive any low impedance load.

However the fourth section of the quad op amp (IC1d), is not required as part of the oscillator, and can therefore be used as a 'no extra cost' output buffer amplifier, providing a low impedance output. This enables the oscillator to easily drive other circuits or such devices as a small loudspeaker.

Notice that this design uses low pass, rather than the high pass filters that are common in BJT phase shift oscillator designs.

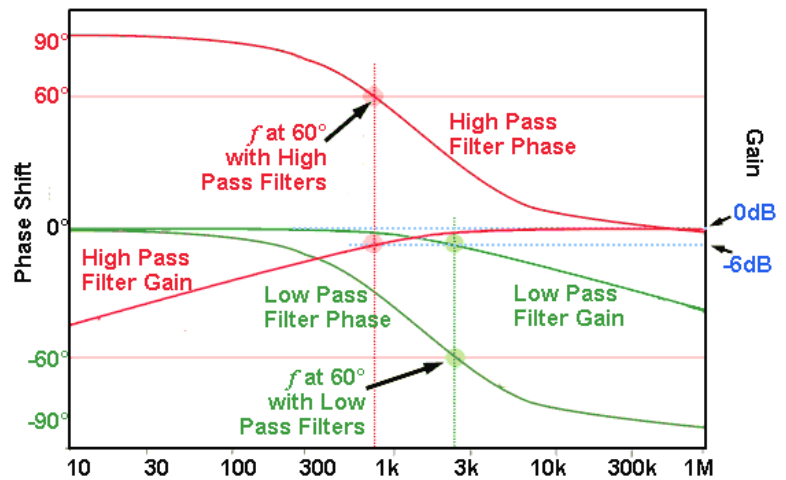

Fig. 3.1.6 Comparison of 60° Frequencies in High & Low Pass Filters

Because the 60° phase shift point in a low pass filter occurs at a different frequency to that in a high pass filter (see Fig. 3.1.6) the frequency of oscillation is higher, around 2.76kHz with low pass filters compared with about 690Hz when high pass filters are used. Fig. 3.1.6 also shows that the gain of an individual filter (high or low pass) is -6dB, which is equivalent to 0.5 in voltage gain, which (being less than 1) is a loss. Therefore the three low pass filters in Fig. 3.1.5 will contribute a total loss of 0.5 x 0.5 x 0.5 = 0.125 or 1/8th, meaning that for a closed loop gain of 1 the amplifier will need a gain of 8.

To make sure the oscillator starts up however, a slightly higher gain is needed, so the gain of IC1a is set by R1 and R2 as 1M/120k = 8.33. This is considerably lower than the gain of 29 required for the BJT version in Fig.3.1.4.

In Fig. 3.1.5 there is virtually no loading of the filter circuits, due to the presence of the op amp buffers. Because the frequency of oscillation of the buffered amplifier shown in Fig. 5 is higher than that in Fig.3.1.4, due to its use of low pass filters, the frequency of oscillation for Fig. 3.1.4 and Fig. 3.1.5 must be calculated differently.

Although both oscillators use the same values for R and C (10KΩ & 10nF), the BJT version shown in Fig. 3.1.4 has its frequency is calculated as:

$$\begin{aligned}
 f_o &= \frac{1}{2\pi(\sqrt{6})CR} \\
 &= \frac{1}{2\pi \times 2.449 \times 10 \times 10^{-9} \times 10 \times 10^{-3}} \\
 &= 650\text{Hz}
 \end{aligned}$$

However, because the op amp version in Fig. 3.1.5 uses low pass filters, a change in formula is needed:

$$\begin{aligned}
 f_o &= \frac{\sqrt{3}}{2\pi CR} \\
 &= \frac{1.732}{2\pi \times 10 \times 10^{-9} \times 10 \times 10^{-3}} \\
 &= 2.76\text{kHz}
 \end{aligned}$$

The loading effect, or lack of it can also affect the frequency, changing the actual frequency of a practical phase shift oscillator from the calculated value, theoretically by as much as 25% in BJT circuits.

However, when the two oscillators described here were tested, the error between the calculated and actual frequency in both cases was less than 7%; within the error range expected due to component tolerances, this is another problem that is greater with phase shift oscillators than LC oscillators, due to the increased number of components (three RC pairs controlling the frequency instead of just one LC pair in LC oscillators).

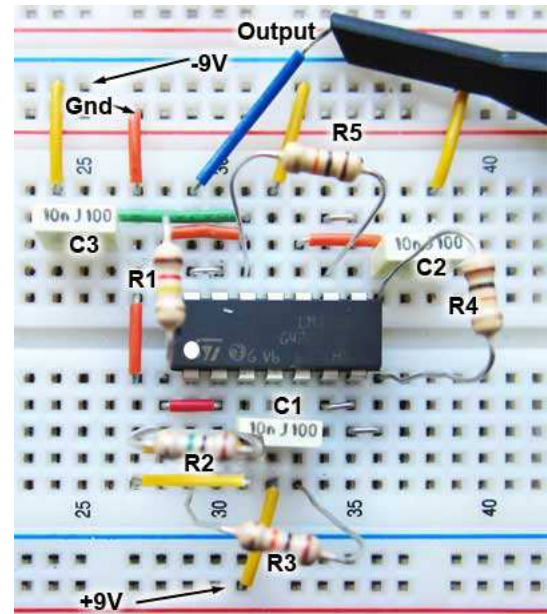

Fig. 3.1.7 Buffered Phase Shift Oscillator on Breadboard

## Oscillators – Module 3

### 3.2 BJT Phase Shift Oscillator Practical Project

#### What you'll learn in Module 3.2

After Studying this section, you should be able to:

- Build a Phase Shift Oscillator from given instructions.
- Test a Phase Shift Oscillator for correct operation.
- Take measurements on a Phase Shift Oscillator.

#### Building a Phase Shift Oscillator

Try this circuit out for yourself; download full constructional details to build the phase shift oscillator shown in Fig 3.2.1 using either breadboard (proto board) or strip board, then test the oscillator's operation using a multi-meter and oscilloscope. A really effective way to learn about oscillators!

This Phase Shift oscillator produces a sine wave output in excess of 3V<sub>pp</sub> at an approximate frequency set by the values chosen for the filter components. Other values may be used to vary the frequency obtained.

The circuit will operate from a 9V battery, or a DC power supply of 9 to 12V. Supply current at 9V is less than 1mA.

The circuit can be built on breadboard as shown in Fig 3.2.2 for testing purposes. To make the amplifier gain variable, R6 can optionally be replaced by a 1K variable resistor. This can be adjusted to find the value that gives the best wave shape and reliable amplitude.

#### Construction on Breadboard

##### Components List.

- TR1 = 2N3904
- C1, C2 & C3 = 10nF
- C4 = 10µF
- C5 = 100µF
- R1 = 100K
- R2, R3 & R4 = 10K
- R5 = 4K7
- R6 = 390R

#### Additional Components For Stripboard Version

- Strip board 9x25 holes
- 3 way connection block (Optional)
- 9V battery connector (Optional)
- Tinned copper wire (for links)
- Insulated flexible wire(for external connections)

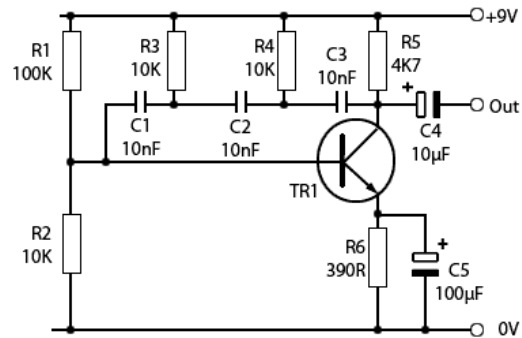

Fig. 3.2.1 Phase Shift Oscillator

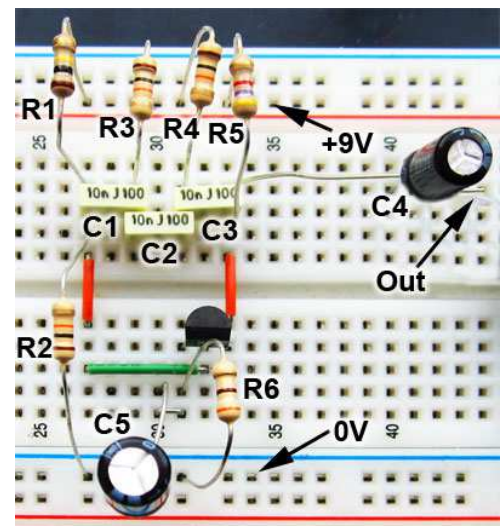

Fig. 3.2.2 Phase Shift Oscillator Breadboard Version

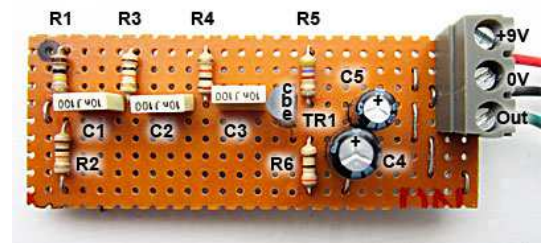

Fig. 3.2.3 Phase Shift Oscillator Stripboard Version

### Construction - Stripboard Version

1. On a piece of 9 x 25 hole strip board, mark hole A1 on both sides of the board as shown in Fig. 3.2.4 to ensure that counting the strips and holes for placing track cuts and components always starts from the same point.
2. Mark the holes where track cuts are to be made. Double check their correct position before cutting.
3. Make the track cuts.
4. Solder the wire links in place.
5. Solder the components in place in the following order.
  6. Resistors.
  7. Polyester capacitors.
  8. Transistor (check for correct e b c positions before soldering).
  9. Electrolytic capacitors, (check for correct polarity before soldering).
  10. Terminal Block.

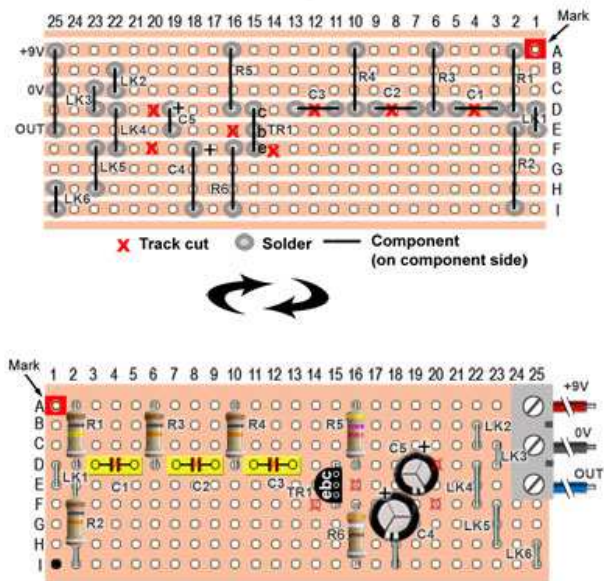

Fig. 3.2.4 Phase Shift Oscillator Layout on Stripboard

Carefully check for any short circuits made by solder bridging adjacent tracks, and for any poorly soldered joints.

Connect up the power supply, and connect an oscilloscope to the output.

Once the circuit is oscillating reliably, carry out the tests indicated on the Phase Shift Oscillator Measurements Test Sheet.



### BJT Phase Shift Oscillator Measurements

Having built the phase shift oscillator, either on breadboard or strip board, check that the circuit is oscillating satisfactorily by displaying the output waveform on an oscilloscope.

1. Calculate the design frequency of the oscillator using:  $f_o = 1/2\pi(\sqrt{6})CR = \underline{\hspace{2cm}}$  Hz.
2. Using a multi-meter, take the DC measurements and complete Table A.
3. With an oscilloscope connected to TR1 collector (not the circuit output terminal) draw at least two cycles of the collector waveform on the grid below. Enter the time/division and volts/division settings of the CRO in the spaces provided.
4. From the waveform, calculate and record the values in Table B.

Table A	
The supply voltage	
The supply current	
TR1 collector voltage	
TR1 base voltage	
TR1 emitter voltage	

Table B	
Peak to Peak Voltage	
DC level of the wave	
Periodic time T of the wave	
Frequency of the wave (1/T)	

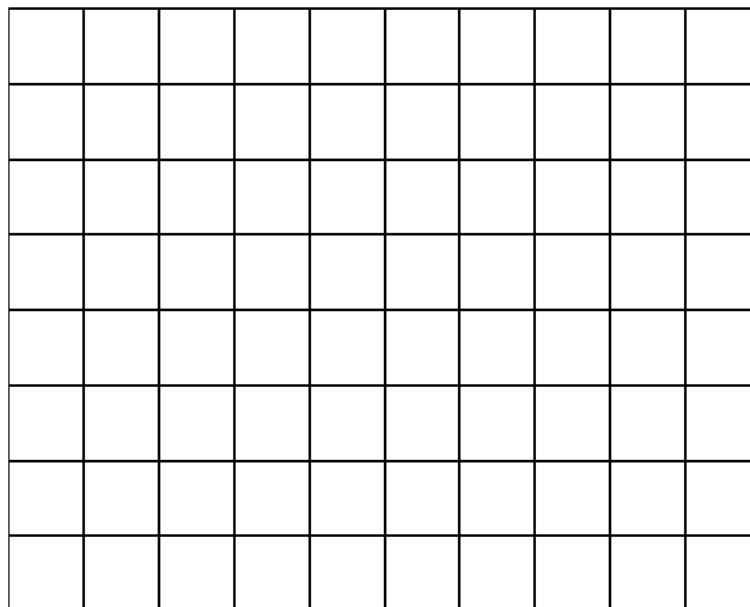

\_\_\_\_\_ V/Div

\_\_\_\_\_ μs/Div

## Oscillators – Module 3

### 3.3 The Wien Bridge Oscillator

#### What you'll learn in Module 3.3

After studying this section, you should be able to:

- Understand the operation of the Wien Bridge Circuit.
- Calculate the frequency of a Wien Bridge oscillator.
- Understand the relationship between gain and phase in a Wien Bridge oscillator.
- Recognise the need for gain control.

#### The Wien Bridge Circuit

For frequencies much below 1MHz RC oscillators become more practical than LC types because of the physical size and expense of the inductors and capacitors required at low frequencies. A problem arises with RC oscillators however, when a variable frequency is required.

In LC oscillators a single tuned circuit controls the frequency, which can be changed simply by making either a single inductor or a single capacitor variable. The frequency of oscillation in RC types, such as the [phase shift oscillator](#), is controlled using multiple RC combinations to produce the correct amount of phase shift at the required frequency.

To alter the frequency, it is therefore necessary to alter the value of at least three components, either resistors or capacitors simultaneously. Even though it is possible to manufacture ganged variable capacitors, the size of capacitors needed at low (e.g. audio) frequencies means that the capacitors would have to be physically too large to be practicable.

It is also possible to manufacture multiple variable resistors but much more difficult to ensure that the tracking of such components is accurate enough, i.e. as the resistance of the multiple resistors is varied, they must each change their resistance at exactly the same rate. Again the cost of suitable components becomes impractical for many purposes.

In addition, it is possible to build Wien Bridge oscillators having very low levels of distortion compared with Phase Shift designs.

#### The Wien Bridge

The original Wien Bridge circuit shown in Fig. 3.3.1 was developed in 1891 for the purpose of accurately measuring capacitor values. To find the unknown value of C1 for example, when the other component values are known, an AC signal is applied across the circuit and the value of another component (e.g. R1) is varied by a calibrated potentiometer. At some point, the bridge will 'balance' when the ratio of resistances in the R3/R4 arm matches the ratio of impedances in the two halves of the arm including C1, R1, C2 and R2. This will be indicated by both sides of the ammeter 'bridge' being at the same potential so the meter indicates zero current. At this point it is possible to calculate the value of the unknown capacitor C1.

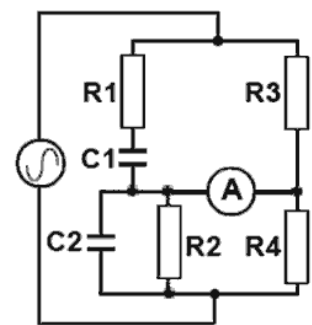

Fig. 3.3.1 The Wien Bridge

A second use for the Wien Bridge is to measure an unknown frequency. If all the component values are known, the same bridge balancing procedure can be used to measure, by calculation, the frequency of the AC supplied.

### Oscillators – Module 3

#### 3.4 Wien Bridge Oscillators

#### What you'll learn in Module 3.4

After studying this section, you should be able to:

Understand the operation of Wien Bridge Oscillators.

- Lamp controlled circuits.
- Diode controlled circuits.
- AGC controlled circuits.

Construct a lamp controlled Wien Bridge oscillator from given instructions.

#### Building Wien Bridge Oscillators with Modern Components

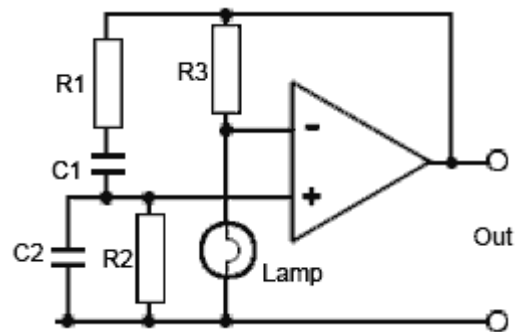

Fig. 3.4.1 Basic Lamp Stabilised Wien Bridge Oscillator

The Wien Bridge oscillator can still be built using similar principles to the early Hewlett Packard versions, but with modern components.

Fig. 3.4.1 shows a basic Wien Bridge Oscillator using a filament lamp with an op amp. It is a property of filament lamps that the resistance of the tungsten filament increases in a non-linear manner as the filament heats up. The lamp in Fig. 3.4.1 is connected in the negative feedback potential divider that sets the gain of the non-inverting amplifier. The gain of the amplifier is set by:

$$\frac{(R3 + R_{LAMP})}{R_{LAMP}}$$

Therefore the greater the resistance of the lamp the lower the amplifier gain. By choosing a suitable lamp, the gain of the amplifier can be automatically controlled over an appropriate range. Usually a lamp with a maximum current flow of around 50mA or less is used, to give an initial gain of more than 3 as the oscillator starts, falling quickly to 3 as the lamp heats up.

Hewlett's original 1939 design used a high voltage vacuum tube (valve) and relatively large lamp, with modern low voltage semiconductors however, it is not easy to find suitable filament lamps that have a suitable voltage range and a low enough current to avoid overloading the amplifier, although useful lamps can still be found, usually of the wire ended T1 or 'grain of rice' types but even they are becoming more difficult to find in component suppliers catalogues, as LED types become more popular for low voltage lighting.

Fig. 3.4.2 shows a low current filament lamp designed to work from 5V at 45mA, and Fig. 3.4.3 is a graph taken from a typical example, showing how its positive temperature coefficient resistance varies with voltage. (Note that resistance without any temperature dependant characteristics would be a straight line). The useful area of the lamp characteristic, where the largest change in resistance occurs is shaded green, the oscillators amplitude is stabilised by making use of this area. However, because filament lamps are not made as electronic control devices, manufacturers do



Fig. 3.4.2 Typical T1 Miniature Filament Lamp Compared With a Match Head

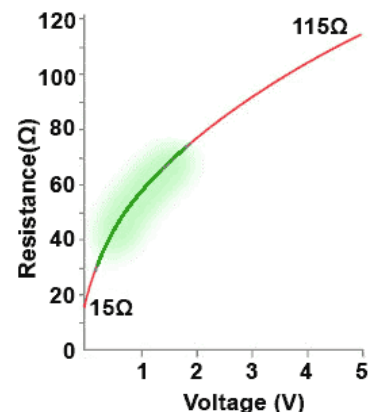

Fig. 3.4.3 Non-linear resistance of a filament lamp

not usually provide graphs such as that in Fig.7 so, when using a lamp as a stabilising component it is necessary to first construct a graph for the lamp to be used, and decide on the active area.

The gain of the amplifier in Fig. 5 depends on the ratio of the values of the feedback resistor R3 and the lamp. For oscillations to start, the amplifier gain needs to be greater than 3, but to work correctly after the initial start up the gain must be 3. Using the formula:

$$\frac{(R3 + R_{LAMP})}{R_{LAMP}}$$

This requires the lamp to be half the resistance of the feedback resistor R3 to provide the necessary gain of 3, but slightly less than twice the resistance of R3 at start up.

To find a value for R3 that will give the correct amount of gain at start up and during oscillation, its value should be slightly greater than twice the value of the lamps resistance at the lower end of the green shaded area (i.e.  $2 \times 30\Omega = 60\Omega$ ) to give a gain  $>3$ , but no greater than twice the value of the lamp's resistance at the upper limit of its useful slope (i.e.  $2 \times 75 = 150 \Omega$ ), the gain should then stabilise at 3, with the oscillator providing an undistorted sine wave output.

To obtain an undistorted output at a specific amplitude, it is useful to initially use a [variable resistor](#) of about 1kΩ in place of the feedback resistor. Varying the resistor will show the limits between the greatest amplitude before distortion and the smallest amplitude for stable operation. The resistance of the variable control can then be measured find the value of feedback resistor that provides a stable and undistorted wave of acceptable amplitude. In a test circuit, built using a LM324 op amp with a supply voltage of  $\pm 9V$  to  $\pm 12V$  a value of 68Ω to 82Ω proved ideal.

To find values for R and C in the Wien Bridge that will give a specific frequency:

The formula for frequency:

$$f_{osc} = \frac{1}{2\pi RC}$$

Can be re-arranged as:

$$R = \frac{1}{f_{osc} 2\pi C} \quad \text{and} \quad C = \frac{1}{f_{osc} 2\pi R}$$

These calculations will almost inevitably produce values that do not match available components so it will be necessary to choose a [preferred value](#) closest to the calculated one. It may be possible to make up an odd value from two preferred values to get closer to the required frequency, remembering that component tolerances will make absolute accuracy difficult to obtain. The test circuit shown in Fig. 3.4.4 used 10K and 100nF, which gives a calculated frequency of 159Hz, the measured frequency turned out to be 157Hz. The output wave is shown in Fig 3.4.5.

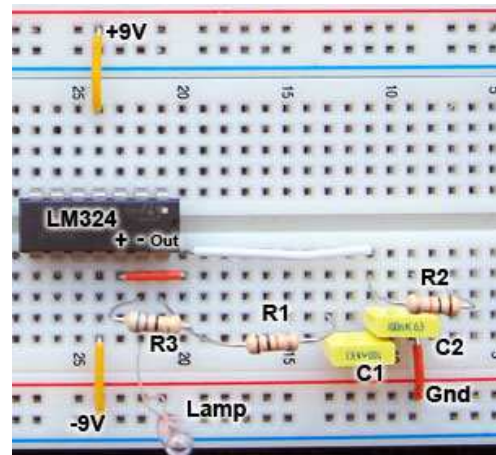

Fig. 3.4.4 Lamp Stabilised Circuit on Breadboard

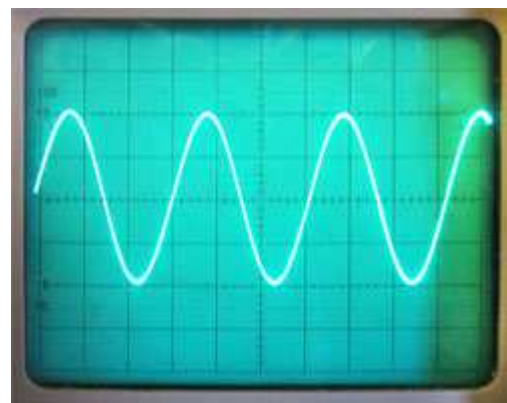

Fig. 3.4.5 Output Waveform from Lamp Stabilised Circuit

### Construction on Breadboard

The circuit in Fig. 3.4.1 can be built on breadboard using Fig 3.4.4 as a guide, and calculating the values of C1, C2, R1 and R2 from the information above. Experiment with your own values, but for initial testing purposes, a list of components used in the circuit shown in Fig 3.4.4 is given below

#### Components List.

- IC1 = LM324
- C1 & C2 = 100nF
- R1 & R2= 10KΩ
- R3 = 68Ω
- Lamp = T1 5V 45mA wire ended lamp
- At the time of writing (2013) [suitable lamps](#) are available from [Rapid Electronics UK](#)

#### Lamp Stabilised Wien Bridge Oscillator Measurements

Having built the Wien Bridge oscillator on breadboard check that the circuit is oscillating satisfactorily by displaying the output waveform on an oscilloscope.

1. Calculate the design frequency of the oscillator using:  $f_{osc} = \frac{1}{2\pi RC}$  \_\_\_\_\_ Hz
2. Using a multi-meter, take the DC measurements and complete Table A.

Table A	
The +V supply	
The -V supply	

3. Record the chosen value for the feedback resistor R3 \_\_\_\_\_ Ω

4. With an oscilloscope connected to the oscillator output, draw at least two cycles of the output waveform on the grid below. Enter the time/division and volts/division settings of the CRO in the spaces provided.

5. From the waveform, calculate and record the values in Table B.

Table B	
Peak to Peak Output Voltage	
DC level of the wave	
Periodic time T of the wave	
Frequency of the wave (1/T)	

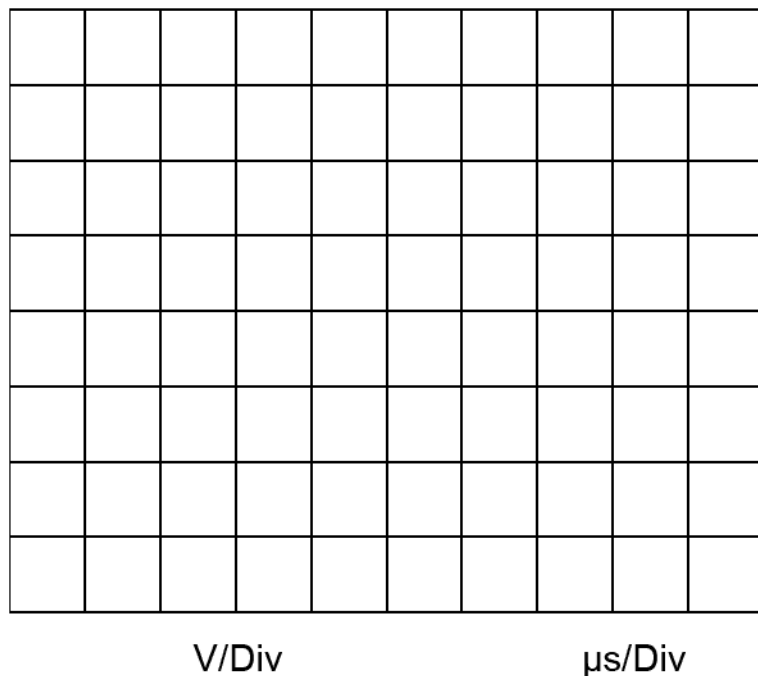

### Diode Stabilised Wien Bridge Oscillator

An alternative to lamp stabilisation is provided by using a pair of diodes in parallel with the feedback resistor as shown in Fig. 3.4.6.

In this circuit the gain of the non-inverting amplifier is controlled by the ratio of R3 to R4. Initially the gain set by R3 and R4 will be just slightly greater than 3, this will allow oscillations to start.

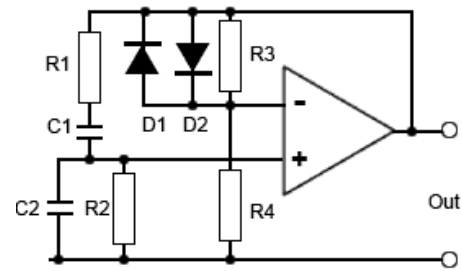

Fig. 3.4.6 Basic Diode Stabilised Wien Bridge Oscillator

Once the signal fed back from the output produces a waveform across R3 that approaches 0.6Vpp the diodes will begin to conduct. Their forward resistance will reduce, and because they are in parallel with R3, this effectively reduces the value of R3 and so reduces the amplifier gain.

The main problem with this method is that the output wave can be more prone to distortion than in the lamp stabilised circuit, as the diodes will tend to distort the waveform peaks if the gain set by R3 and R4 is slightly higher than needed. This also means that the oscillator's output amplitude is somewhat restricted if distortion is to be minimised.

Fig. 3.4.7a shows that with the correct gain, producing an output of 1.2Vpp and the diodes just on the edge of conducting, the circuit provides an undistorted output, but with only a slight increase in output to 1.4Vpp the diodes start to

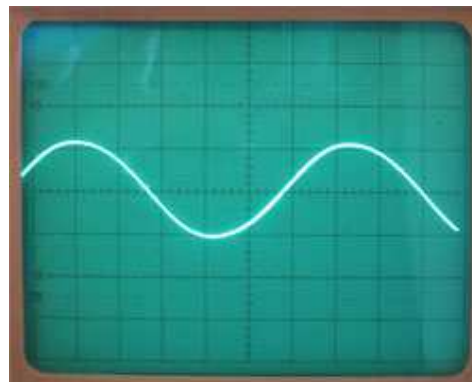

Fig. 3.4.7a Correct Gain Gives Undistorted Output at 1.2Vpp

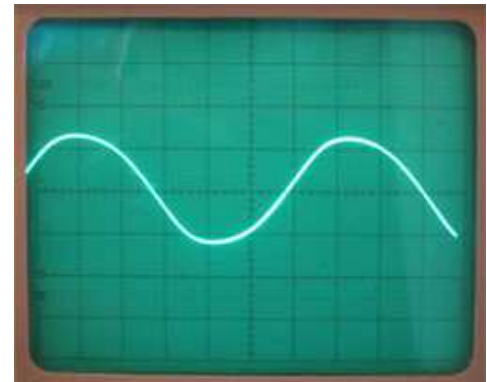

Fig. 3.4.7b With Output at only 1.4Vpp Output Starts to Distort

conduct more heavily and slight distortion is already becoming apparent. Careful examination of Fig. 3.4.7b shows the peaks of the sine wave are just beginning to be asymmetrical, with the rising slope of the wave steeper than the falling slope. Any further increase in output would cause greater distortion.

### Variable Frequency Wien Bridge

Fig. 3.4.8 shows a practical diode stabilised circuit with variable frequency that can be built on breadboard to learn by experiment.

The range of frequencies may be extended using different capacitor values for C2 and C3 as indicated in the diagram. The gain of the amplifier is set by the ratio of R1 to R2 and R2a at 3.04. If R2a is omitted the gain increases to 3.136, which still gives an output but with slightly increased distortion as shown in Fig. 3.4.7b.

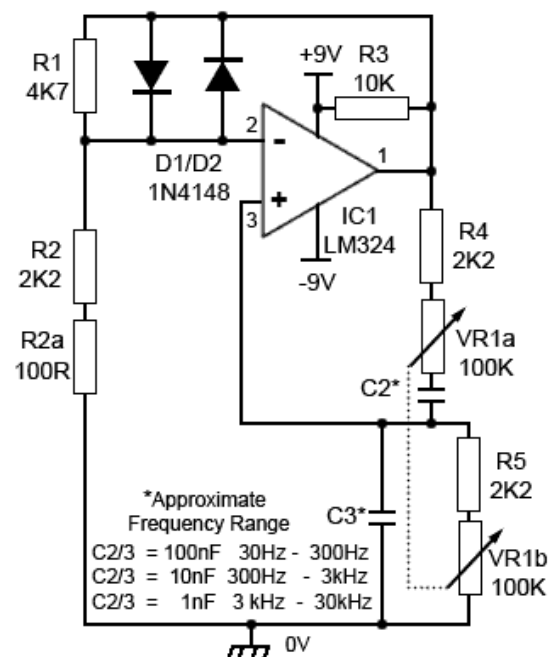

Fig. 3.4.8 Diode Stabilised Variable Frequency Wien Bridge Oscillator

An interesting experiment is to replace R2/R2a by a variable resistor (4k7) and see the margin between distortion (too much gain) and failure to oscillate (too little gain) by slightly changing the gain.

The values of the gain setting components in Fig. 3.4.8 are carefully chosen to give a gain just greater than 3. It is the ratio of the component values rather than the values themselves that govern the amount of gain. What is the effect if R1, R2 and R2a are replaced by 47K, 22K and 1K respectively?

### Potentiometer problems

Some problems crop up when using real components on breadboard that do not readily show up in computer simulations. These include a particular problem when using variable resistors in Wien Bridge oscillators.

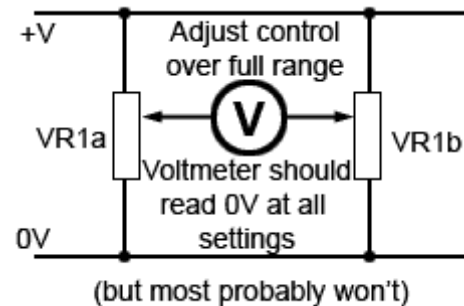

Fig. 3.4.9 Testing Potentiometer Tracking

Ideally both resistors in a [dual potentiometer](#) would have identical resistance values. Small differences are normally not noticeable when using these potentiometers in stereo audio systems for example, but unless a considerable amount is spent on buying special potentiometers that not only have matched resistances but also each change resistance by exactly the same amount as the wiper contacts of both resistors move, quite small mismatches can cause problems in circuits such as the Wien Bridge.

The resistance from the wiper to either end of the resistance track should be identical on both controls for any angle of rotation of the control. The effect of inaccurate tracking is that at some angles of rotation, VR1a and VR1b may not be equal values and the balance of the bridge circuit is upset, then the amplitude of oscillation may vary, or oscillations may even cease altogether. A simple method of testing the tracking ability of a dual potentiometer is shown in Fig 3.4.9.

Both potentiometers are connected across a low voltage supply, (low enough voltage to avoid excessive current through the control), and a voltmeter connected between the two sliders. As the control is adjusted over its full range, the voltage on both sliders should be the same and so the voltmeter will always read zero volts. It is most likely that with standard potentiometers the reading will not remain at zero but the test can help in choosing the most suitable dual control.

### Crossover Distortion

The circuit suggested in Fig. 3.4.8 uses one section of an LM324 quad op amp, which has an output that works in class A but changes to class B with large signals. This can make it susceptible to [crossover distortion](#). The recommended way to eliminate this is to force the output to work in single ended class A mode by connecting an external resistor between the output and either ground or supply. In this circuit a 10K resistor (R3) to supply eliminates crossover distortion. For different signal and supply levels the value of R3 may need to be varied, again - experiment.

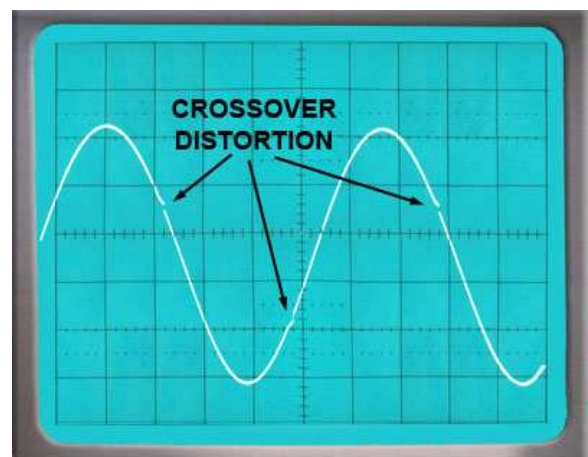

Fig. 3.4.10 Crossover Distortion in the LM324 Output

### Wien Bridge Oscillator with AGC

A JFET can be used to provide automatic gain control (AGC) as shown in Fig 3.4.11. This can provide a larger amplitude output and less distortion than the diode version, and unlike the lamp stabilised version, uses readily available components.

This circuit has a variable frequency using a dual ganged potentiometer arrangement similar to the diode stabilised circuit, with R6 and R7 reducing the load on the amplifier output if the bridge potentiometers are adjusted to zero ohms. R5 is added to prevent crossover distortion problems.

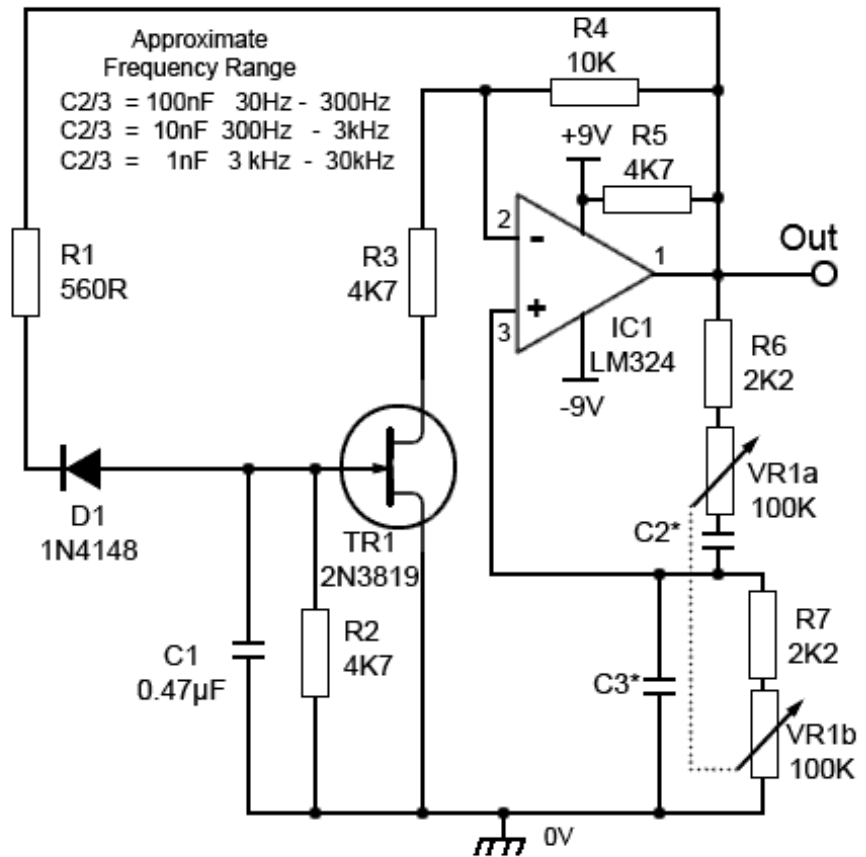

Fig. 3.4.11 Wien Bridge Oscillator with AGC

Fig. 3.4.12 shows an experimental Wien Bridge AGC oscillator built on breadboard. It has useful frequency ranges as shown in Fig. 15 although the output can be found to reduce in amplitude at the extreme upper frequencies (above the range indicated) in each range, due to the loading of the output by the low resistances of the potentiometers. Fitting higher value resistors for R6 and R7 reduces this effect

but also restricts the frequency range.

Fig. 3.4.13 illustrates a typical sine wave output at 1kHz 10Vpp.

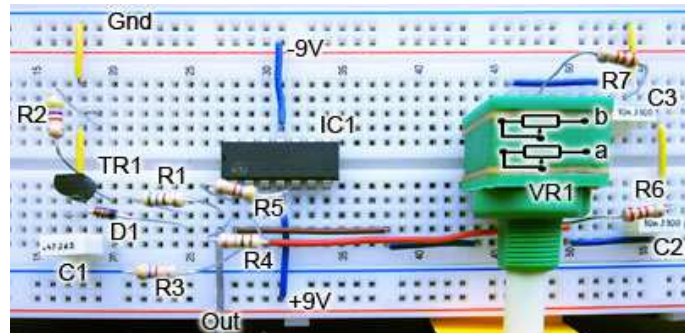

Fig. 3.4.12 AGC Wien Bridge Oscillator on Breadboard

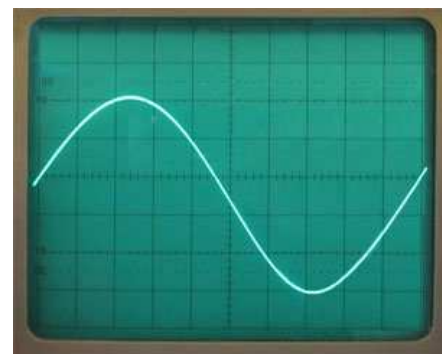

Fig. 3.4.13 AGC Wien Bridge Output 10Vpp 1kHz



### Automatic Gain Control (AGC)

Fig. 3.4.14 shows a computer simulation of the oscillator waveforms during the first 45ms after start up, and how the AGC system stabilises the amplitude of the output wave. The output wave of IC1 is coloured green and the input signal is shown by the blue waveform. The controlling voltage applied to the gate of TR1 is coloured red. The numbers in circles refer to the numbered paragraphs below.

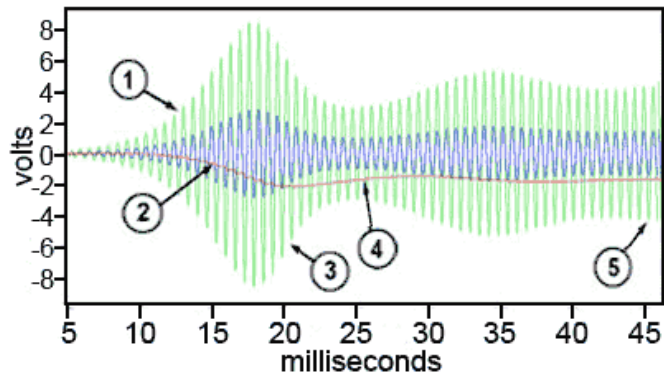

Fig. 3.4.14 AGC Action at Start-up

The gain of the amplifier is initially set by the ratio of R4(10K) and R3(4K7)

$$Gain = \frac{10K + 4K7}{4K7} = 3.13$$

1. For the first few milliseconds after switch on, the voltage on TR1 gate is 0V, therefore the drain/source channel has a very low resistance compared with R3 and the gain of the amplifier is 3.13, and after 5ms the output waveform begins to grow rapidly.
2. The output wave is fed back to D1, which rectifies the negative half cycles of the wave to produce a negative DC voltage that grows negatively as C1 charges.
3. As TR1 gate becomes more negative, the resistance of the [JFET](#) increases, adding to the resistance of R3 and reducing the amplifier gain.
4. The output amplitude falls too far, slightly over compensating, but this reduces the negative gate voltage allowing the output to increase again.
5. After about 45ms the gate voltage  $V_{GS}$  settles at about -2V and the system stabilises the gain at 3 and the input wave can now be seen to be 1/3 of the amplitude of the output wave.

### 3.5 AF Oscillator Quiz

Try our quiz, based on the information you can find in Oscillators Module 3. You can check your answers by using the online version at:

<http://www.learnabout-electronics.org/Oscillators/osc35.php>

1. Refer to Fig. 3.5.1. How much is the feedback signal phase shifted by C3, R4?

- a) 90°
- b) 60°
- c) 45°
- d) 30°

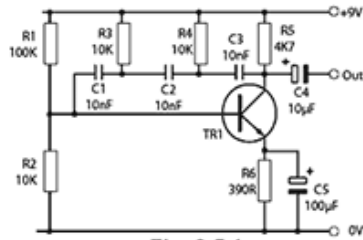

Fig. 3.5.1

2. Refer to Fig. 3.5.1. What is the approximate frequency of oscillation?

- a) 440Hz
- b) 550Hz
- c) 650Hz
- d) 2.7kHz

3. An advantage of Wien Bridge oscillators compared to Phase Shift types is that::

- a) Wien bridge oscillators can be used over a much wider frequency range than Phase Shift types.
- b) It is easier to make variable frequency oscillators with Wien Bridge types than Phase shift types.
- c) Wien bridge oscillators can use op-amps.
- d) Wien bridge oscillators always have a lower output impedance than Phase Shift types.

4. If each low pass filter in Fig. 3.5.2 has a voltage gain of 0.5, how much gain will be required from the amplifier for oscillations to start?

- a) 1
- b) 1.3
- c) 8.3
- d) 29

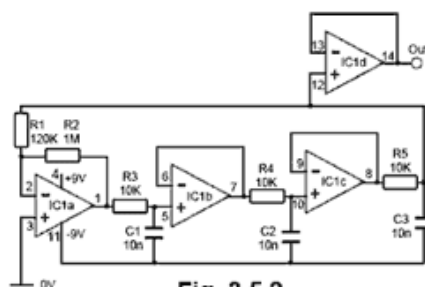

Fig. 3.5.2

5. Refer to Figs. 3.5.2.and 3.5.1 Which of the following comparisons is true?

- a) Frequency calculation is more complex in Fig. 3.5.2 than in Fig. 3.5.1.
- b) The filters used in Fig. 3.5.2 cause less distortion than in Fig. 3.5.1.
- c) Loading on the phase shift networks in Fig. 3.5.2 is reduced, compared to Fig. 3.5.1
- d) The output impedance of Fig. 3.5.2 is higher than that of Fig. 3.5.1

6. Which formula in Fig 3.5.3 should be used for finding the frequency of oscillation of a buffered phase shift oscillator?

- a)  $f_o = \frac{1}{1.4RC}$       b)  $f_o = \frac{1}{2\pi(\sqrt{6})RC}$
- c)  $f_{osc} = \frac{\sqrt{3}}{2\pi RC}$       d)  $f_o = \frac{1}{2\pi\sqrt{RC}}$
- Fig. 3.5.3

7. If the circuit in Fig. 3.5.4 is supplied with an AC signal and the ammeter reads zero amperes, what is the phase relationship between points X and Y?

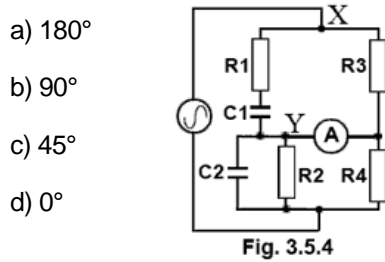

8. What is the purpose of the lamp in Fig. 3.5.5?

- a) To stabilise the frequency of oscillation.  
b) To indicate the oscillations are present.  
c) To prevent distortion  
d) To give over current indication.

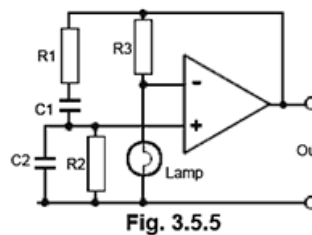

9. Refer to Fig 3.5.6. What is the purpose of TR1?

- a) To provide automatic gain control (AGC) for IC1  
b) To provide automatic frequency (AFC) control for IC1  
c) To provide a high impedance input for the feedback system.  
d) To provide a constant current DC supply for IC1.

10. Refer to Fig 3.5.6. What is the approximate low frequency limit of the Oscillator?

- a) 70Hz  
b) 150Hz  
c) 1.5kHz  
d) 7kHz

